

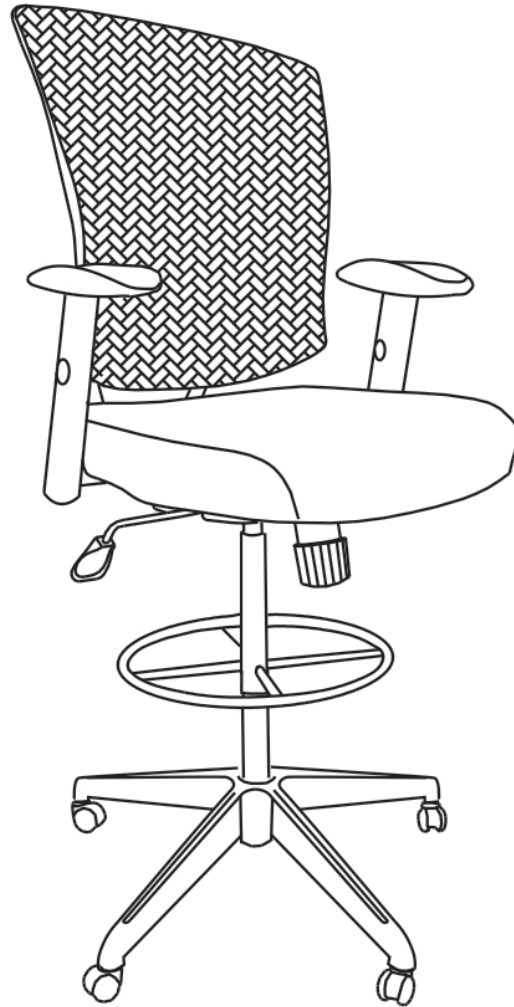

**SCAN HERE**  
to see additional  
information and  
product videos



**Tools Required**

Allen key provided.  
No additional tools required.

**Parts Included**

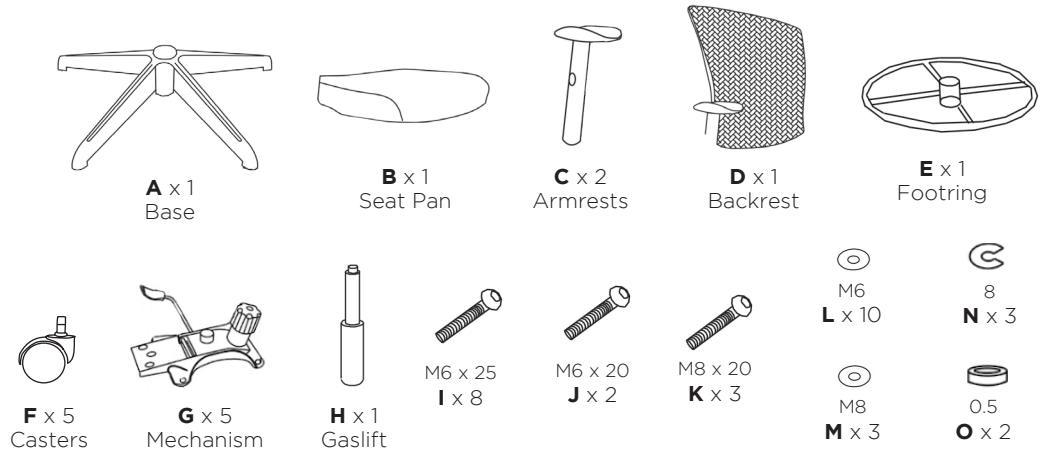

### Step 1

Insert casters into base. Insert gaslift into base. Slide footring over the gaslift and tighten knob at desired height.

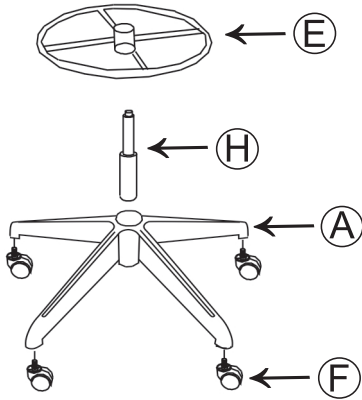

### Step 2

With seat pan upside down, attach armrests marked L (left) and R (right) to seat using screws (I) and washers (L) shown below and tighten with Allen Key.

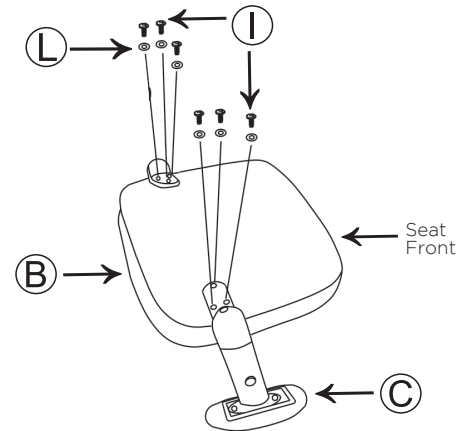

### Step 3

With seat upside down, place mechanism on the seat aligning so the "Front" label on the mechanism matches the front label on the seat pan. Use two screws marked (J) and two screws marked (I) and flat washers (L) to attach the mechanism. Tighten fasteners once all fasteners are in using Allen Key

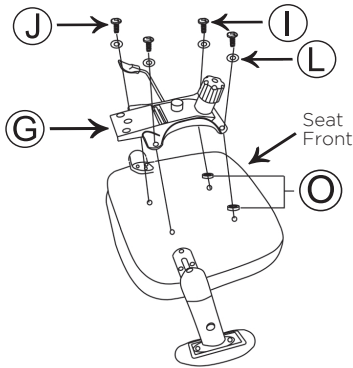

### Step 4

Attach backrest to mechanism using 3 back screws (K) and washers (M, N) shown below. Tighten screws using Allen Key.

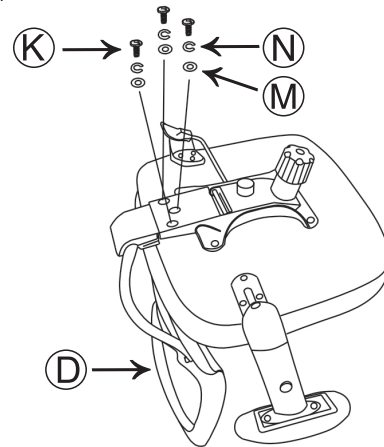

### Step 5

Attach assembled chair to base and gaslift. Sit on the chair to secure.

